

OL 770-ADMS

Automated Display Measurement System



The OL 770-ADMS is an integrated solution for automated display measurements. The system combines the versatile OL 770 Spectroradiometer with precise modular positioning stages. The OL 700-MPXYZ 3-axis Translation Stage locates the imaging telescope (OL 610/620), and the OL 700-MPHV Dual Axis Goniometer orients the device under test at the required measurement angle. The two stages and the OL 770 Spectroradiometer are coordinated by a powerful scripting software package. Example scripts are available for standard VESA FPD measurements. Users can write or adapt scripts to meet custom test requirements or to perform standardized measurements on virtually any type or size of display.

Accessories	
	700-430 Scripting Software
	700-MPC 5-Axis Motion Controller
	700-MPXYZ 3-Axis Translation Stages
	700-MPHV Dual Axis Goniometer
	700-MPH 1-Axis Goniometer (horizontal)
	700-MPC2 2-Axis Controller

SPECIFICATIONS *

OL 700-MPXYZ 3-Axis Linear Motion Stage	
X Axis Motion Range	17.8 cm (7.0 in)
Y Axis Motion Range	17.8 cm (7.0 in)
Z Axis Motion Range	8.6 cm (3.4 in)
Drive Screw Pitch	5.0 mm (0.19685 in)
Incremental Resolution	0.0125 mm (0.0005 in)
Positional Accuracy	0.050 mm (0.002 in)
Positional Repeatability	0.0125 mm (0.0005 in)
Maximum Load Capacity	6.0 kg (13.2 lbs)
OL 700-MPHV Dual Axis Goniometer	
Rotary Motion Range	180° total (± 90° from normal incidence)
Angular Resolution	0.005°
Angular Accuracy	< 150 arc-sec (0.04°)
Angular Repeatability	< 50 arc-sec (0.01°)
Maximum Load Capacity (device under test)	4.5 kg (10 lbs)
OL 700-MPC Motion Controller	
Power Input	Universal 100 to 240 VAC 50-60 Hz
Power Consumption	200 W
Computer Interface	RS232 Serial Interface or Ethernet Interface

*Custom configurations, ranges, and maximum capacity loads can be provided

Application Software

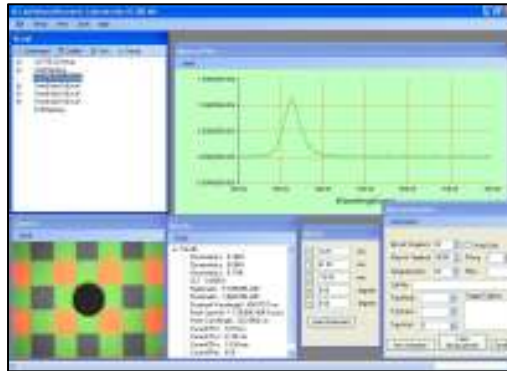

Sample scripting environment

Automated measurement processes in the OL 770-ADMS is user-friendly scripting environment. Features include:

- Plug-in architecture
- Ability to write custom scripts, performing complex motion control in conjunction with optical measurements
- Scripting capabilities of both Excel and PowerPoint
 - Advance targets in PowerPoint
 - Set cell on any worksheet or spreadsheet for data collection and automated analysis
 - Set groups of cells with scan data
- Windows XP and Vista compatible
- Create complete control sequences in Visual Basic format
- Custom built-in functions for:
 - User-determined input parameters
 - User decisions
 - Warnings about system situations or conveying step procedures
- Completely expandable and scalable
- Plug-ins can be used as standard .NET DLLs for user out programming environment
- Drivers as .NET DLLs

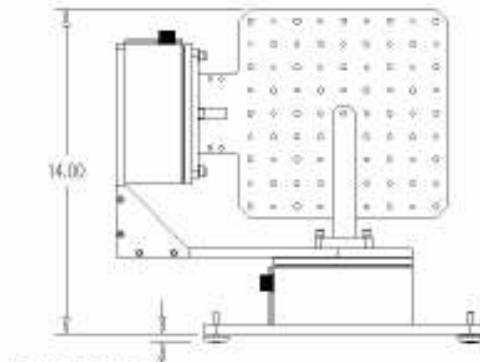

OL 700-MPHV Dual Axis Goniometer

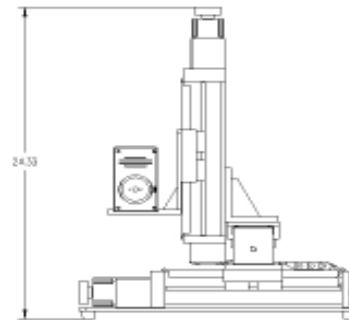

OL 700-MPXYZ 3-Axis Transition Stage

See Bulletin 250 on the OL 770-DMS Display Measurement System for further information on related products.