

OL IS-470-WP

Submersible Integrating Sphere Assembly

Ideal for Applications such as:

- Measurements of solar UV in coastal and tidal regions.
- Measurements of UV absorption with depth.
- Supplemented lighting levels in fish farming cages.
- Comparative PAR and UV irradiance levels.
- *Ground truth* measurements.

The OL IS-470-WP Submersible Sphere Assembly is a sealed, 4-inch diameter integrating sphere suitable for underwater measurements up to a depth of 20 meters. The sphere uses a dual port design with a 90° port configuration, and contains an internal baffle before the exit port to permit only integrated light from exiting the sphere. Optical delivery to the OL 756 Optics Head is via an OL 730-7Q-WP Waterproof Fiber Optic Probe. The OL IS-470-WP and OL 730-7Q-WP assembly are usable over the 280nm to 1100nm wavelength range. The operating temperature range is -5°C (non-submersed) / 10°C (submersed) to 50°C.



A submerged OL IS-470-WP connected via OL 730-7Q-WP waterproof fiber optic to an OL 756 Portable Spectroradiometer on the surface.

- Suitable for air and underwater measurements.
- Maneuvers easily to required depths.
- Suitable for downwelling and upwelling measurements.
- Small shadow in upwelling measurements.
- Can be supplied with long light guide to isolate spectroradiometer from harsh environments.
- Reduced risk of damage and loss of Spectroradiometer.
- High accuracy cosine correction over wide spectral range.
- Supplied with immersion effect factors.
- High stability.
- Low maintenance.

SPECIFICATIONS

Internal Sphere Diameter	4 inches (10.16 cm)
Fiber Optic Light Guide Length.....	up to 20 meters (65 feet)
Depth	20 meters (65 feet)
Weight.....	4 kg (9 lbs.)
Coating (Wavelength Range)	200 nm to 2500 nm
Coating: Pressed PTFE.....	Average reflectance 99%
Dome Window (Wavelength Range).....	280 nm to 1100 nm
Dome Window Diameter.....	3.25 inches (8.25 cm)

Dimensions:

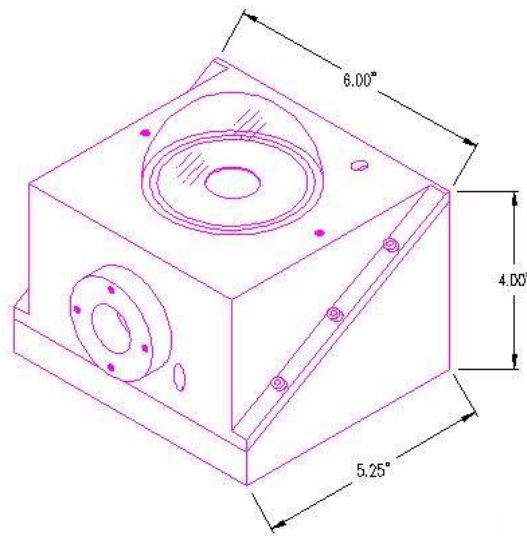

Schematic:

