

OL 731 USB Smart Detector



The OL 731 USB Smart Detector is a low-cost, flexible, programmable, compact radiometer-photometer that can easily be set up for specialized needs. A range of sensors and filters are available to tailor the spectral response to the application - specific requirements. A command set is provided to enable the creation of acquisition programs. As delivered, the OL 731 Series detectors can be operated by any computer with a USB connection.

Optronic Laboratories can provide certified NIST-traceable calibration of the response of each fully configured detector module prior to shipment. The detector can be programmed to read in any user specified radiometric or photometric unit. Calibration factors and optical units can be stored on board.

The OL 731 is supported by an ActiveX™ Software Development Kit, which facilitates user integration into larger process control and monitoring applications. Data can then be automatically transferred into an MS/Excel worksheet using a built-in report utility, allowing for rapid application development.

The OL 731 has a built-in 6 decade preamplifier with automated gain adjustment and a 16 bit ADC. Its firmware manages the details of detector control and data transfer. Its onboard microprocessor communicates with the host computer via a straightforward command set. Several of these versatile detectors can be multiplexed on one Universal Serial Bus.

The Temperature Humidity Sensor is built in to acquire environmental readings for logging, along with the radiometric/photometric data.

The OL 731 USB Smart Detector is suitable for a variety of critical applications including:

- OEM Production Process Control:
 - Display testing and optimization
 - QC
 - UV Curing
 - Photoresist Exposure
- Illuminance Measurement
- Irradiance Measurement
- LED Intensity Measurement

OL 731 Specifications (Typical)	
Detector	UV-Enhanced Silicon
Acquisition rate	500 msec / sample *
A/D resolution	16 bits
Weight	< 0.5 lb.
Operating temperature	40 - 100°F
Operating humidity	0 - 90% non condensing
Power Requirement	5 VDC Via USB connector
User interface	Virtual interface via PC or laptop
Amplifier Gain	10⁴ – 10⁹ Volts/Amp
Calibration	Stored Internally

* Fixed gain setting

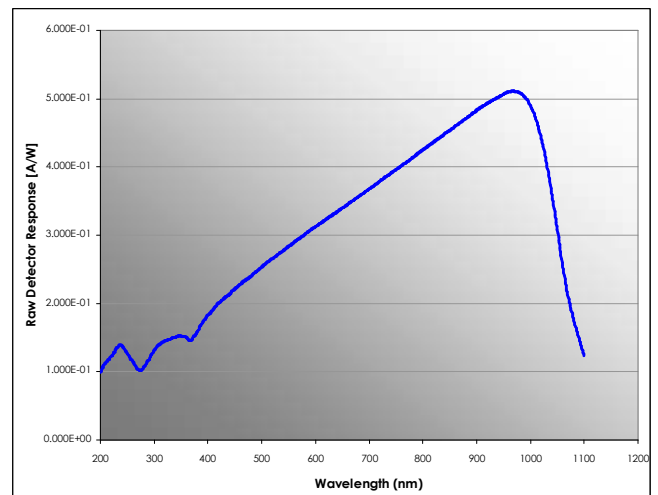

Figure 1 – Raw Silicon Detector Response

OL 731 USB Smart Detector Accessories

A wide selection of accessories is available for use with the OL 731 Smart Detectors that allow it to be easily configured for your custom field or OEM application, including a wide range of optical filters that mount directly onto the detector housing.

- **OL 730-5-PF Photopic Filter** – A photometric correction filter that produces an f_1' factor $< 4\%$ when used with the OL731 USB Smart Detector. “ f_1' ” is a “goodness of fit” parameter, defined by CIE, that compares the spectral response of the photometer to the ideal response.
- **OL 730-5-PF-LED Photopic Filter** - A photometric correction filter that produces an f_1' factor $< 1.5\%$ when used with the OL731 USB Smart Detector. “ f_1' ” is a “goodness of fit” parameter, defined by CIE, that compares the spectral response of the photometer to the ideal response.
- **OL 730-5-RF Radiometric Filter** – A subtractive filter combination that modifies the spectral response of the OL731 USB Smart Detector such that it is relatively flat ($\pm 5\%$) over the wavelength range of 460 nm to 980 nm.
- **OL 730-1, -2, -3 Attenuation Filters** – 10%, 1%, and 0.1% nominally transmitting neutral density filters (quartz) with calibrations for spectral transmittance over the wavelength range of 250 nm to 1100 nm.
- **OL 730-5-XXX Spectral Bandpass Filters** – Narrow band pass interference filters with peak wavelength transmittance and band pass specified by customer.

Measurement Accessories – A wide range of cosine collectors and imaging optics are available to suite the measurement application.

OL 731-SDK Software Development Kit (included) – The Windows XP compatible software development kit allows the user to develop custom applications for the OL731 USB Smart Detector. The software development kit (SDK) provides for high-level control of the instrument. It includes a simple demonstration program and a functional interface for the development of your own custom instrument-control application. The kit is comprised of a panel application with graphical user interface, an ActiveX control, example C++ source code. The ActiveX control functions as an OL731 instrument driver, layered between custom application software, such as the example C++ based panel application, and Windows platform SDK dll's. Source code for the Panel Application is provided as an example for developing your custom client program.



Figure 2 – Panel Application with Graphical User Interface

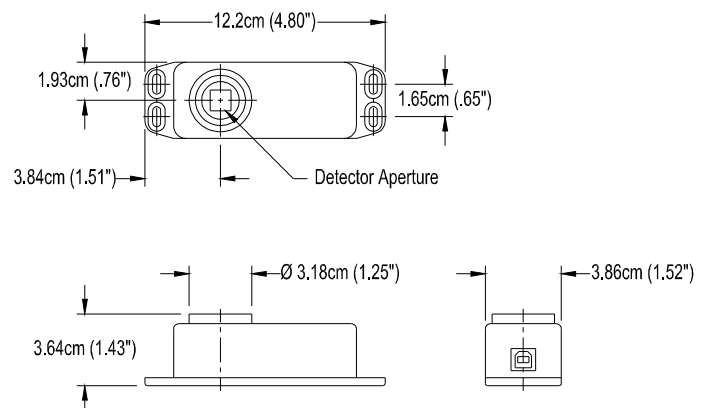

Figure 3 – Opto-Mechanical Layout of the OL 731 USB Smart Detector (shown without filters)