

OL 15AB LED Receptor



- CIE Publication 127 Compliant
- Fast and accurate measurement of LED intensity
- Single versatile assembly adapts to either Condition A or B
- Designed for use with OL 770-LED High-speed LED Test & Measurement System

The OL 15AB LED Receptor is designed specifically for use with the OL 770-LED High-speed LED Test and Measurement System to make fast, accurate measurements of the intensity of Light Emitting Diodes (LEDs). The OL 15AB has been designed in accordance with the CIE Publication 127 measurement recommendations for “**Averaged LED Intensity.**” The geometries of the OL 15AB LED Receptor meet CIE Standard Conditions A and B for “near-field” conditions. The versatile assembly easily adapts to either Condition A or Condition B measurements with a single set of parts. It incorporates unique features such as a fiber/sphere combination that provides uniform spatial response and eliminates major sources of error.

The OL 15AB is designed and built to provide the correct measurement distances for CIE Standard Condition A or B. The distance applies from the tip of the LED to the 1cm² circular aperture. For CIE Standard Condition A, this distance is 316 mm and corresponds to a field-of-view solid angle of 0.001 steradian (sr). For CIE Standard Condition B, this distance is 100 mm, which yields a field-of-view solid angle of 0.01 steradian.

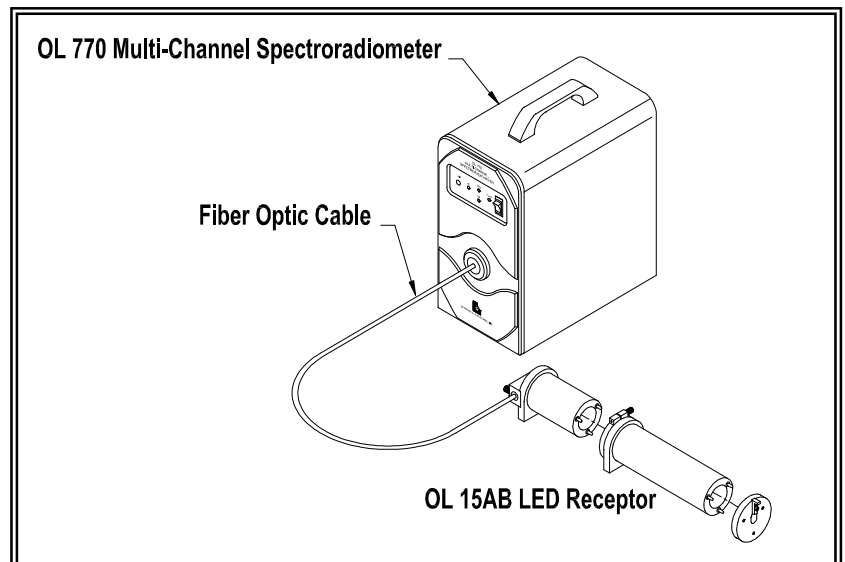

OL 15AB LED Receptor

The OL 15AB consists of a three part machined aluminum tube with internal baffling. The first part includes a 1-cm² aperture, a 1-inch diameter integrating sphere, and the fiber optic connection. This part also includes a short (Condition B) baffle tube. The second part is a longer (Condition A) extension tube. The third part is the removable LED holder. A standard 5-mm diameter (T 1-3/4 size) LED holder is supplied with the OL 15AB, which is interchangeable with other LED accessories such as the OL IS-670-LED Integrating Sphere. Other industry-wide standard size LED holders are available as well as custom holders for specific size and shape LEDs can be provided.

Both baffle tubes for Condition A and Condition B include internal baffles to eliminate any stray light effects through the tube. The Condition A extension tube is easily removed from the main tube to allow Condition B measurements. The extension tube is removed by simply loosening the tube clamp thumbscrew and sliding the two tubes apart.

OL 15AB LED

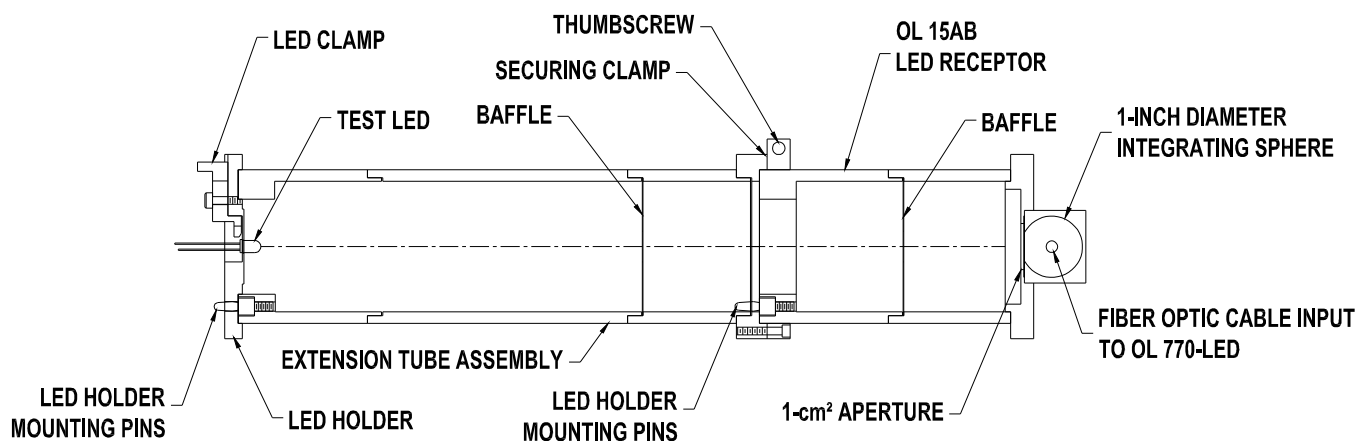

When used with the OL 15 AB, the LED holder snaps into place on either end of the Condition A or Condition B baffle tube. The LED to be tested fits into the mounting hole in the LED holder and is secured in place by a sliding plastic clamp. The LED holder positions the tip of the LED at the correct measurement plane inside the OL 15AB. The LED holder aligns the mechanical axis of the LED with the center of the detector aperture. No other alignment or adjustment is necessary.