

Application Note (A15)

Standard Spheres and Sphere Standards

*Revision: B
February 2001*



OPTRONIC LABORATORIES

A Gooch & Housego Company

Optronicon Laboratories, Inc. 4632 36th Street, Orlando, FL 32811
Tel: 1 407 422 3171 Fax: 1 407 648 5412 Email: info@olinet.com

Standard Spheres and Sphere Standards

Integrating spheres are used in many applications of light measurement, both as input accessories and as standards. Most integrating spheres share some common properties:

1. they are spherical
2. they are coated on the inside with a diffusely reflective coating
3. they generally contain baffles to block “direct light” paths

However, there are many variations in design, and this affects their usefulness for specific applications and their performance. This paper will concentrate on some of the more common applications with established standard designs. In particular:

Standard Spheres

Total Flux Measurements

All the light from a lamp is measured.

Irradiance Measurements

Light at a surface is measured.

Sphere Standards

A large, uniform source that can be used for radiance or luminance calibrations of instruments.

The design features that lead to improved performance for the above sphere applications will be discussed.

Total Flux Measurements

Integrating spheres have some interesting properties. For instance, any part of the sphere surface “sees” all other parts of the sphere surface equally, which means a detector at any point on the surface can measure the total power in the entire sphere. This important fact is the basis for using integrating spheres to measure total flux of lamps. In addition, the reflections from the coating add to the power of the lamp, leading to the fact that there is always more power inside a sphere than the lamp is generating. You can see this happening in large, hinged spheres. As you slowly close the sphere with the lamp on, the light inside the sphere gets brighter and brighter as the open portion diminishes. What you are really seeing is the integration that gives it the name “integrating sphere.”

If a sphere coating has 99% reflectivity, then 99% of the light from the lamp feeds back into the sphere at the first reflection. At the second reflection, this becomes 99% times 99%. At the third, 99% times 99% times 99%, and so on. These reflections continue until all the light is finally lost due to the 1% that isn't reflected, or it hits a detector and is measured. For a large sphere, this means the average number of reflections before it is detected or lost is 99. This might look like the number of reflections and the percentage reflectivity are the same, but the number actually depends strongly on reflectivity and is non-linear. An 80% reflectivity coating gives just 4 reflections on average.

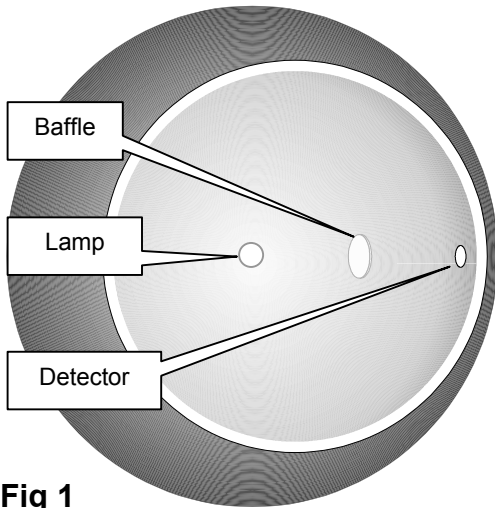

Fig 1

the baffle not only affects light from the lamp hitting the sphere, it can also affect the way the detector “sees” the sphere walls. Figure 2 illustrates the shadow areas created by the baffle. In these shadow areas, the light from the lamp hitting the sphere for the first time (aptly named the “first strike”) is not fully measured. The light must be reflected to another part of the sphere before the detector can see it. Since the sphere coating does not reflect all of the light, these areas represent a lower response than other parts of the sphere. A perfect response would see light from the lamp equally, regardless of direction. Since the baffle is necessary and the baffle creates a non-ideal response, there is no such thing as a perfect sphere for total flux measurements. Practical spheres can come very close however, and just how close depends on attention to small design details.

A typical total flux sphere arrangement is shown in Figure 1. A section of the sphere has been “removed” so you can see what is inside.

The lamp is placed in the center of the sphere, and the detector is on the surface. Between the two, there is a baffle to prevent direct light from the lamp hitting the detector. The sphere and baffle are both coated with a highly reflective material.

It would appear that light from the lamp should hit the sphere wall unobstructed in every direction, with the exception of the area behind the small baffle. However,

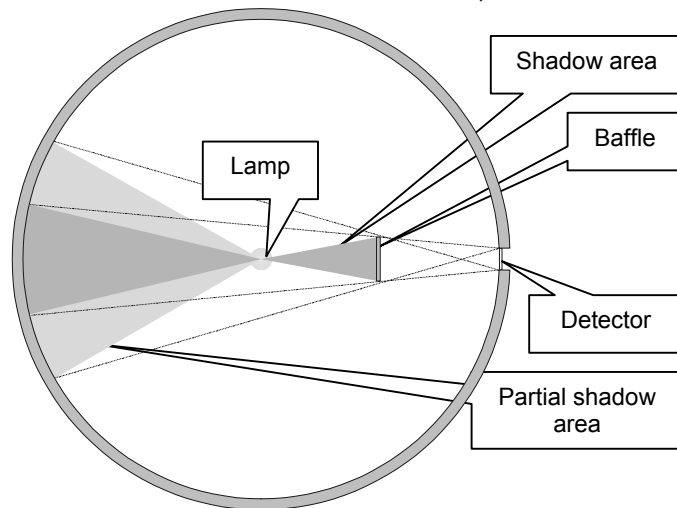

Fig. 2

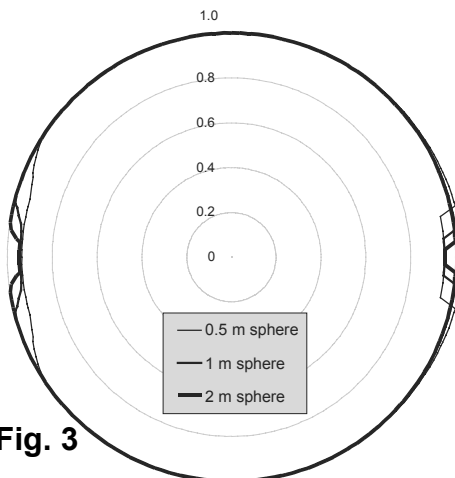

Fig. 3

The plot in Figure 3 is for a sphere coated with a 95% reflective material. The effect of the shadow areas, causing a decrease in responsivity, can be clearly seen to the right and left of the plots. The angular extent of the effect decreases with increased sphere diameter, so a 2 m sphere is much better than a 0.5 m sphere. The change in responsivity in the shadowed regions is only slightly affected by sphere size however, and is due primarily to the coating reflectivity. In the USA, coatings of 98% or more reflectivity are typically used, giving a much more ideal response than that shown. In

Europe, some standards recommend a reflectivity of about 80%, but this gives large geometric errors.

Close inspection of the radar plot also shows a slightly higher than ideal response to the right of the plot, just outside the limits of the baffle. This is due to sphere reflections hitting the baffle on the detector side, increasing the signal at the detector. This increase will occur in all spheres, but it is very dependent on baffle design and can be much worse in some commercial spheres than others.

The sphere responses detailed in the previous sections assume that the detector obeys the cosine law (the cosine law is explained in the irradiance section following). This is essential for the detector to “see” the sphere correctly. If the detector does not obey the cosine law, some angles will contribute more and others less than they should, making it unsuitable for total flux measurements.

Light emission from fluorescent lamps, LEDs and many other sources are highly directional. For best results, these should be oriented so that their strongest emission is directed at the areas of uniform response rather than the shadow areas. Since the extent of the shadow areas decreases with increasing sphere size and decreases with decreasing baffle size, it makes sense to choose a sphere that is as large as possible with baffles as small as possible. This is even more important when the sphere coating has low reflectivity.

If something that absorbs light is placed in the sphere, it will decrease the average number of reflections in the sphere. This is equivalent to decreasing the coating reflectivity and has a dramatic effect on the efficiency of the sphere. Unfortunately, this includes lamps, holders, sockets and cables.

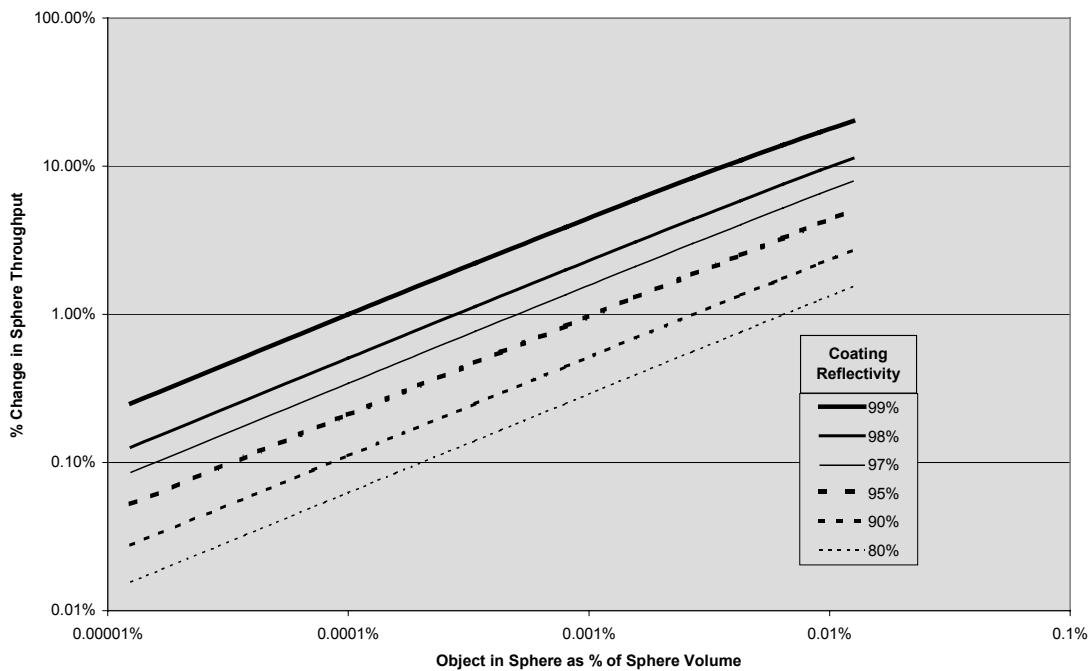
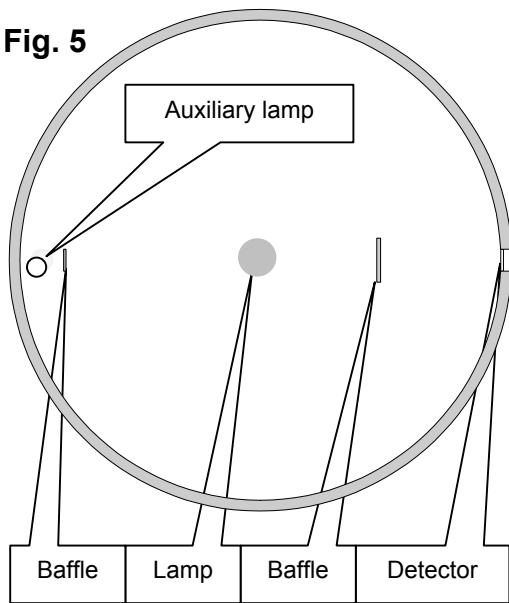

Fig. 4

The graph in Figure 4 shows the effect of a spherical black object placed in the center of the sphere. Changes in sphere throughput are plotted against object volume as a fraction of sphere volume for various coating reflectances. Significant changes in throughput are seen for 99% reflectivity even with an object volume, which is one ten-millionth of the sphere volume. Lower

reflectivity coatings show much less effect from the object. Relating this to an equivalent change in coating reflectivity, the highest values on this plot (at 0.01% object volume) correspond to a coating reflectance change of just 0.25%. This means that anything placed in the sphere has a very significant effect on the absolute response.

Fig. 5



It is unlikely that the standard lamp used in calibration and the test lamp to be measured will be identical. They will therefore have different effects on the throughput of the sphere. To measure a lamp correctly, we have to measure the change in throughput between the standard and test lamps as well as the lamps themselves.

An auxiliary lamp, permanently housed in the sphere, is used to measure the changes in throughput as standard or test lamps, holders, sockets and cables are changed. The auxiliary lamp is normally located on the opposite side of the sphere to the detector in the shadow area to reduce its impact on sphere response, as shown in Figure 5.

The auxiliary lamp is powered up with the standard lamp in the center of the sphere (but not switched on), and

readings are taken from the detector. It is then powered up again with the test lamp in the center of the sphere (but not switched on) and detector readings taken. The ratio of the readings is the change in throughput due to the differences between the lamps. This procedure is normally part of the calibration and does not slow down measurements.

In summary, good measurements of total flux require:

- A large high reflectivity sphere.
- Small, well designed, baffles.
- A cosine collection detector at the sphere wall.
- An auxiliary lamp.

Irradiance Measurements

Irradiance is the light flux falling onto a surface. The light may come from any direction and from multiple sources. The total light falling onto the surface, regardless of the direction it comes from, must be measured.

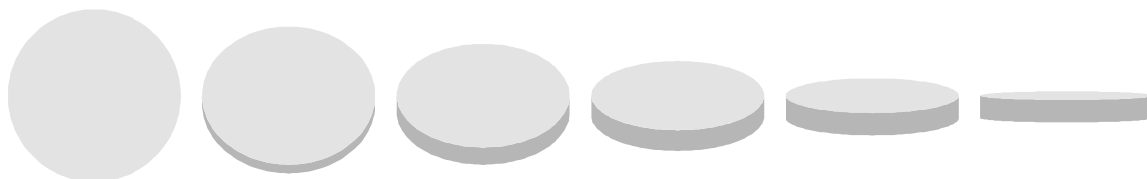

Fig. 6

As shown in Figure 6, the apparent area of any surface varies with the cosine of the angle. This is called the cosine law. A measurement device that obeys the cosine law is called a cosine collector. An integrating sphere with a hole in it to receive external light (input port) makes an excellent cosine collector provided certain design rules are followed.

Rule #1: If light does not obey the cosine law when entering the sphere, there is little the sphere can do to compensate.

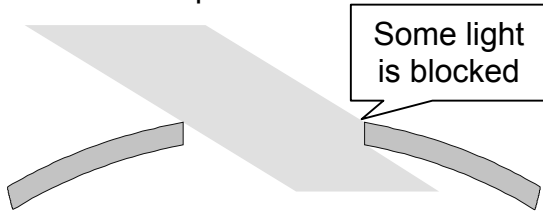

Fig. 7

This might sound like common sense, but it is easier said than done. Spheres have two sides: the inside and the outside. This means that just making a hole in the sphere creates a “tube.” The sides of this tube block some of the light coming in at large angles. This means a tube cannot obey the cosine law.

The answer is quite simple: make the outside of the sphere flat so it meets the inside of the sphere at the port, as shown on the right. This eliminates the tube and allows light to enter the sphere according to the cosine law.



Fig. 8

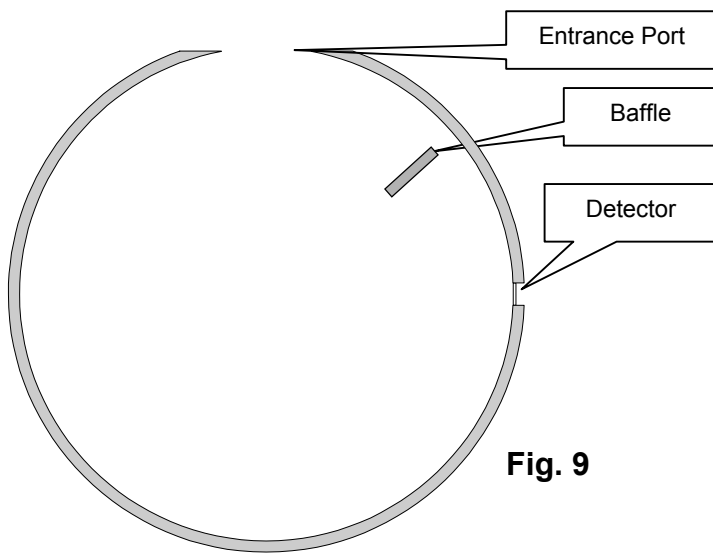

Fig. 9

To complete the sphere, we have:

Rule #2: A baffle is added to prevent direct light from the input port reaching the detector.

Rule #3: The detector must also have cosine law response.

The sphere, shown in the Figure 9, is now suited to measurements of irradiance.

This is the simplest basic design of the Young & Schneider sphere, introduced as a commercial product in 1990.

Sphere Standards

If we take the sphere designed for irradiance and replace the detector with a lamp, it becomes a source of uniform diffuse light. The input port of the irradiance sphere is now the output port of the sphere source. It is very suited to the calibration of instruments for radiance or luminance.

However, the cosine collector is now used in reverse to distribute the light evenly throughout the sphere, and they generally lose a lot of light in the process. This makes it difficult to design a sphere source with high intensity. If the cosine collector is removed, the intensity can be significantly increased, but the source then becomes non-uniform. If the source is required to be variable in intensity, the uniformity may also depend on level of output.

One solution to this problem is to change the design of the sphere. A sphere with a central baffle like the one shown in Figure 10 is used. By making sure the input light hits only the baffle, the output is randomised and uniform. A monitor detector

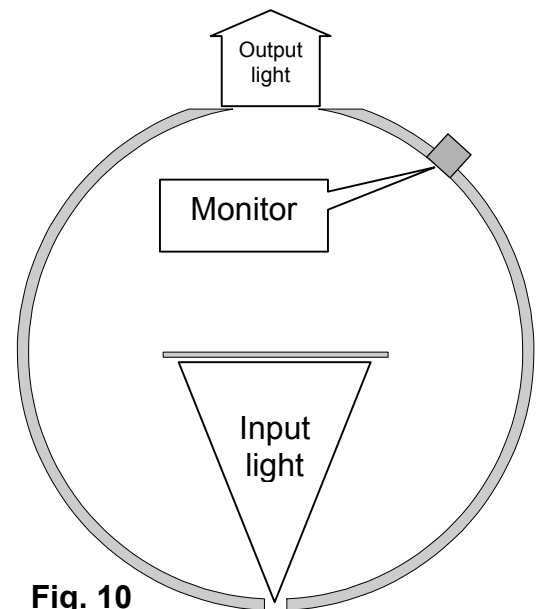

Fig. 10

is added, which has a restricted view so it only “sees” the output side of the baffle. Since the output light comes from this baffle, the monitor detector can be calibrated to read the output level directly. So, if we vary the level of input, we can read the level of the corresponding output.

The level of input is normally adjusted using a variable slit. Non-imaging concentrating optics can be used to increase the levels, but only if the biggest slit is over-filled. Ideally, the intensity of light at the slit would be approximately uniform so the input light can be varied smoothly. The type of slit used can affect the ease of adjustment and the range of intensity however. There are two main types of slit in common use: linear (or 1D) slits that change their width only, and area (or 2D) slits that change their height and width together.

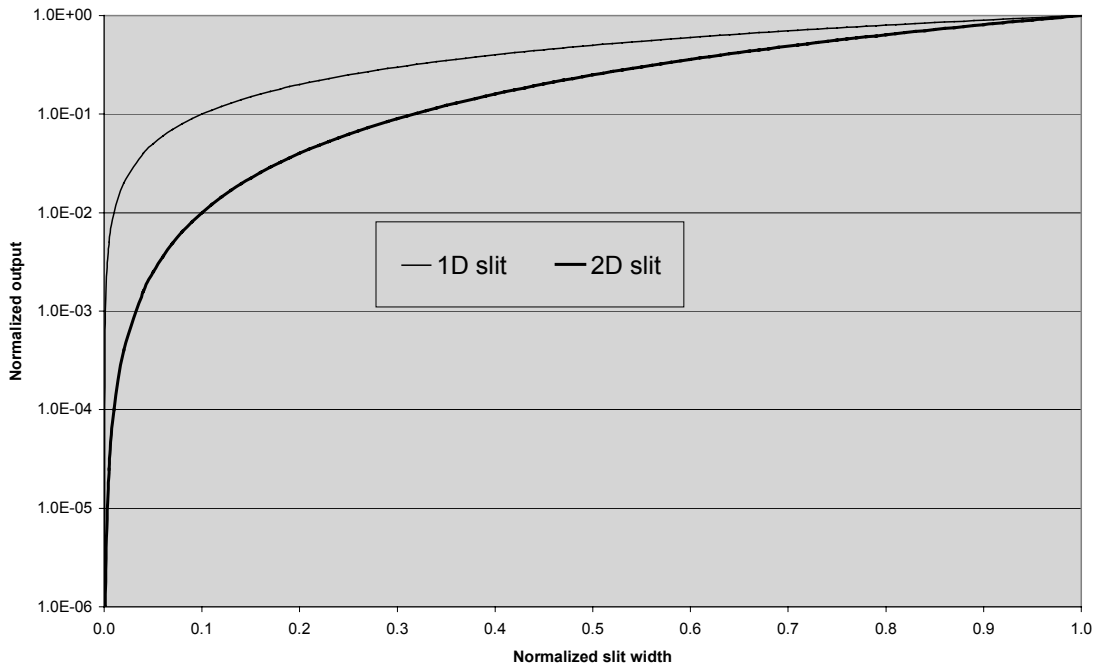

Fig. 11

When looking to design a sphere with a large dynamic range, a 1D slit will have problems at lower light levels. As you can see from the graph in Figure 11, the output (on a logarithmic scale) drops very sharply with slit width after 2 or 3 decades reduction. The 2D slit continues to provide adjustment up to 5 or 6 decades.

Expressed another way, we can define a resolution to the adjustment. This might correspond to the smallest practical movement of the slit, whether manual or automated. If we then look at how big this resolution needs to be to change the output level by 1% for all possible intensities, we can appreciate the true dynamic range of the sphere source in terms of practical use.

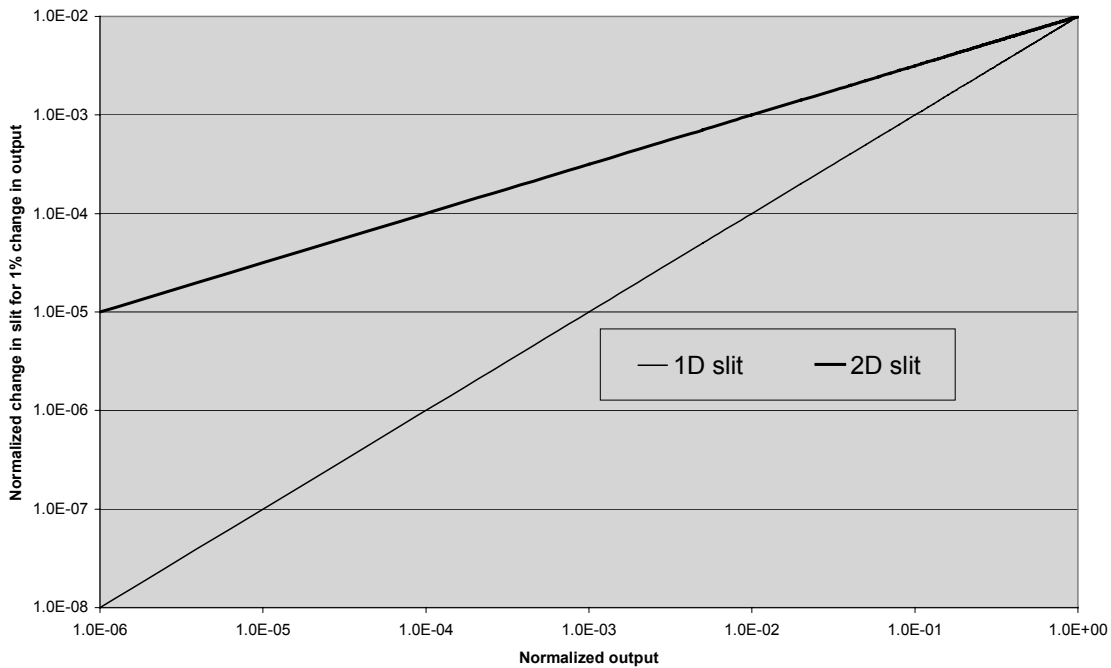

Fig. 12

Figure 12 shows that to adjust the output intensity by 1% when it is 6 decades below maximum would require the slit width to be varied with a resolution of 1 part in 100,000,000 (10^{-8}) of its full scale. A 2D slit could perform this same adjustment with a slit movement that is 1000 times bigger, and therefore easier to achieve. Clearly, the 2D slit is far superior in this application. It offers no advantages when adjusting intensities close to the maximum however, where either can be used equally effectively.

In summary, by careful design (like the one described above) and selection of materials, it is possible to make an integrating sphere standard that has:

- High uniformity of output
- High maximum levels of output
- Very stable operation
- Up to 6 decades of light level adjustment
- Direct reading of the output
- Easy adjustability and setting to any level
- An almost constant spectrum at all levels